

# NORWIK



Product name	<b>Instant Electric Water Heater</b>
Dimension	product: 32*23*13cm, inner paper box:27.5*24.5*16cm, carton: 50.5*38.4*52 cm
Package	1pc/ inner paper box, 6pcs/ carton
Loading q'ty	1620pcs for 1*20ft, 3420pcs for 1*40ft, 4020pcs for 1*40HQ
Min q'ty	1*20ft container loading q'ty
	<p>Instant Electric Water Heater (finished product: assembled &amp; packed)</p> <ol style="list-style-type: none"><li>1. Two contact only for getting more power depends the water flow in coming.</li><li>2. <b>For 8.8 kw, 40 AMP, 220V/60HZ.</b> <b>Temperature 36-75°</b> <b>Working Water Pressure 0.4-6.5 kgf/cm<sup>2</sup></b></li><li>3. The cables made with connector .</li><li>4. The safety thermal starter at 85 degree as requested.</li><li>5. The switch can be made 3 option + OFF, and front panel have the same information).</li><li>6. By adding one more LED (became to 2 LED)</li><li>7. Fisher (Metal Hunger), and User Manual</li><li>8. Without shower.</li><li>9. Without Chromed Heater</li></ol>

**NORWIK**

**SJ602**

**INSTRUCTION MANUAL  
INSTALLATION AND OPERATION**

**NORWIK**



**ELECTRIC WATER  
HEATER**

**CENTRESS INTERNATIONAL HK LIMITED HONGKONG**  
T: 0086 20 38843058/38843108 Fax: 0086 20 38843309 E-mail: chris@soceve.com.cn

**PLEASE READ THIS MANUAL CAREFULLY BEFORE OPERATING YOUR  
EQUIPMENT. KEEP THIS MANUAL HANDLED FOR FUTURE REFERENCE.**



### 3.2 Maintenance

The periodicity of the maintenance depends very much on the quality of the water supplied to the heater. In the cold water inlet of the heater is a filter to prevent the entrance of impurities to it. When this Filter is covered, the flow of water passing to the device decreases, therefore it must be cleaned occasionally. To clean the filter, cut off any electrical supply to the heater, disconnect the power supply wires and water connections, lift the heater, and run water under pressure in the opposite direction. In cases where the water contains many solid impurities, it is advisable to place an independent external filter for easy cleaning. The water from springs and deep wells has a high content of minerals that solidify quickly in the resistance, in these cases it is necessary to perform a preventive maintenance, where it is necessary to descale the calcium salts adhered to the resistance, once every 6 Months. In these cases it is highly recommended the placement of water softeners in order to improve water quality and thus prolong preventive maintenance.

Model: \_\_\_\_\_ Serial: \_\_\_\_\_

Adquired in: \_\_\_\_\_ Date: \_\_\_\_\_

Installed by: \_\_\_\_\_ Date: \_\_\_\_\_

### 3.3 Maintenance History

Date	Technician Name	Maintenance performed	Parts replaced

Observations: \_\_\_\_\_  
 \_\_\_\_\_  
 \_\_\_\_\_  
 \_\_\_\_\_  
 \_\_\_\_\_

### Important:

- Read the technical instructions before installing or operating this unit.
- Install the heater with qualified technical personnel for the guarantee to be effective.
- Never make improvised or temporary electrical connections. Connect this unit to ground.
- Purge the air from the unit by circulating the water before connecting the power supply.
- Install this unit as close as possible to the hot water supply point.
- The water from springs and deep wells has a high content of minerals that solidify quickly in the resistance, in these cases it is necessary to perform a preventive maintenance, where it is necessary to descale the calcium salts adhered to the resistance, once every 6 Months and and it is advisable to use softeners and filters to improve water quality

### INDEX

<b>1. CHARACTERISTICS</b>	<b>3</b>
11 General Characteristics	3
12 Dimensions and names of external parts	3
13 Names of internal parts	4
14 Technical characteristics	4
15 Electrical Diagram	5
<b>2. INSTALATION</b>	<b>5</b>
2.1 Accessories included in the packaging	5
2.2 Place of assembly	5
2.3 Heater assembly	5
2.4 Water connections	6
2.5 Electrical Instalation	6
<b>3. USE AND MAINTENANCE</b>	<b>7</b>
3.1 Operation	7
3.2 Maintenance	9
3.3 Maintenance History	9

## 1. CHARACTERISTICS

### 1.1 General Characteristic

#### Operating Comfort:

Select the desired heating power (temperature setting) between minimum, medium or maximum and when the hot water faucet is opened, the heater will turn on automatically, heating the water for as long as required.

Has a water flow regulator, with which it can decrease or increase the amount of water circulating through the heater and consequently the water temperature.

#### Security:

Safety system against over-heating and against over-pressure of water. Only with safety breaker against electrical deficiencies. Water connection at the bottom for maximum safety. Equipped with water valve which determines the automatic ignition of the heater, by pressure and water flow.

#### Efficiency:

You will never run out of hot water (DO NOT HAVE TANK).

Turns on automatically only when the hot water is opened for Maximum electricity savings.

#### Comfort:

So small that fits anywhere and easy installation.

#### Durability:

Advanced design WITHOUT ELECTRONIC CARD, guaranteed long useful life. Housing in thermoplastic material of high quality, STAINLESS.

### 1.2 Dimensions and name of external parts

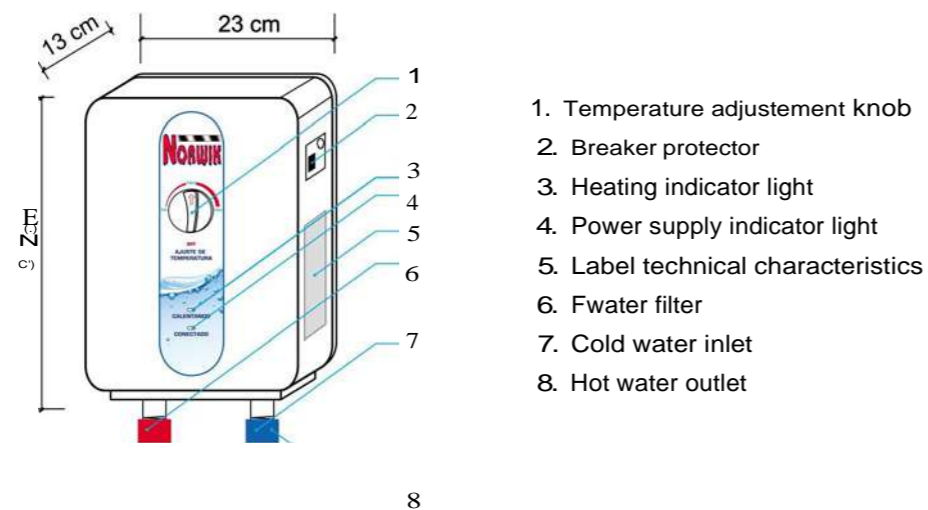

Your Norwick heater is equipped with four independent safety systems:

1. Safety device against overheating of the water, which cuts off the electric supply to the heater in case the water exceeds 90 degrees (if this device were activated, the breaker of the heater must be reset and the cause of the activation must be checked).
2. Safety device against water overpressure, which relieves any pressure increase caused by water thus avoiding internal damage.
3. Breaker safety device which cuts off the electrical supply to the heater in case of alteration or deficiency of the electric supply. (If this device were activated, the heater breaker should be reset and the cause of the activation checked).
4. Water valve, which determines the automatic ignition of the heater. In case the pressure or water flow is not adequate (very low) will not turn on the heater avoiding internal damages.

Fig.1: Water flow regulator settings

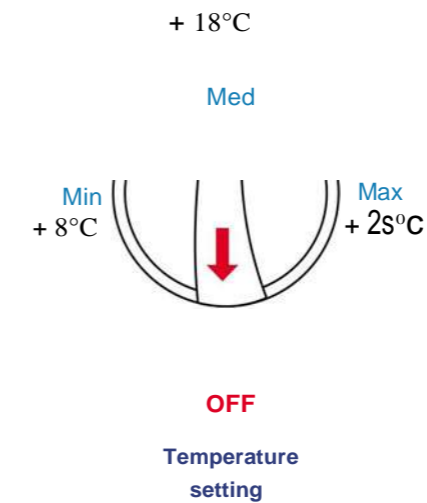
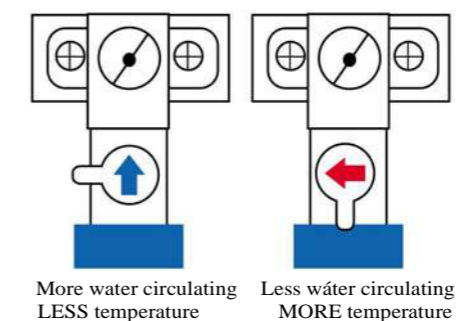

Fig.2: Water flow adjustment



## IMPORTANT

Connect the equipment's ground cable to a grounding system as for example: metal water pipe, electrical cabinet or buried copper bar, this is the ultimate route of landing.

It is recommended that the electrical installation be carried out by a professional electrician or by personnel qualified by our company for the guarantee to be valid.

## 3. Use and Maintenance

### 3.1 Operation:

Before supplying electricity to the heater, we must be sure that all the air has been purged from the interior of the appliance, for which water must be allowed to run through it by opening the hot water faucet for one minute. Check that there are no water leaks in the water connections, you can use a dry napkin, placing it around the connections and making sure that it is not wet or wet. Turn the breaker on the main board and then on the heater breaker. At this time the "connected" indicator light on the front panel of the heater must illuminate, ie the heater is already supplied with power. Place the desired heating position in the temperature setting selector (see figure 1.)

Passing a water flow of 6 lts / min through the heater, this will raise the water temperature, relative to the cold water temperature in:

- 1)"Minimum" position, the heater increases the water temperature by approximately 8 ° C
- 2) "Medium" position, the water temperature will be approx. 18 ° C.
- 3)"Maximum" position, the temperature will be raised to 25 ° C above the cold water temperature.

Your Norwik heater has a device in the cold water inlet with which you can regulate the flow of water passing through your heater and consequently the temperature of it. (See figure 2), for example, if the water flow rate is decreased to 3 lts / min, the heater will increase by 50 ° C relative to the cold water inlet temperature, ie at a higher water flow rate Heater less temperature and less water flow plus temperature.

To know in a practical way the flow of water passing through your heater perform the following operation: deposit in a container the water leaving the heater during the time of 1 minute. Count the liters of water contained in the container and the result will be the liters of water circulating through the heater in the time of 1 minute. (Lts / min).

Once the desired temperature has been selected, turn on the hot water tap and the heater will turn on automatically, at this time the "Warming up" indicator light should have been lit in order that the heater is running, ie heating the water. When the hot water tap is turned off, the heater will turn off automatically.

## 1.3 Name of internal parts

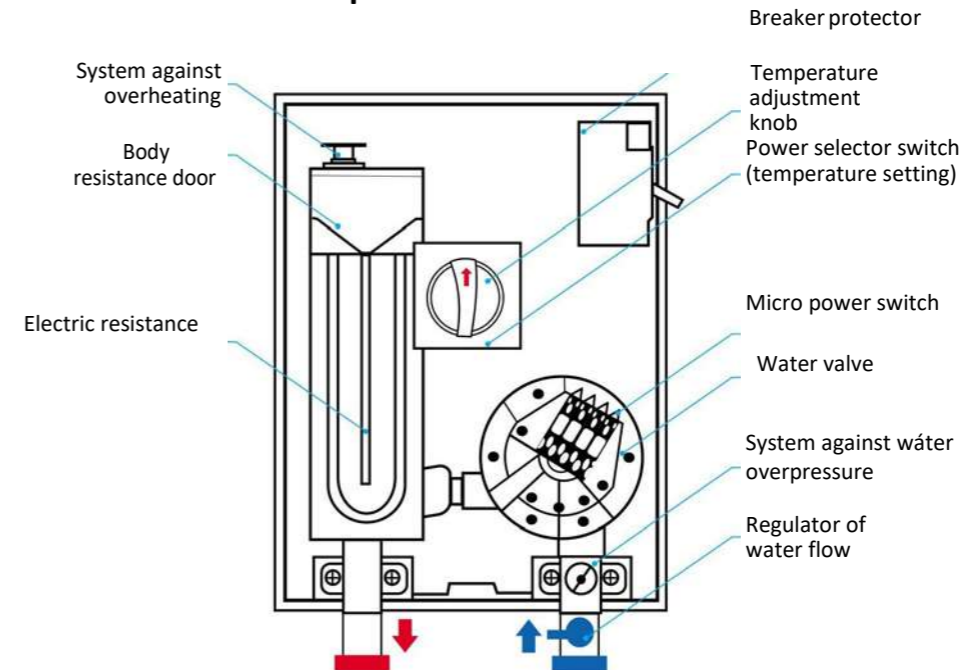

## 1.4 Technical Characteristics

Model	SJ602					
Voltage	220 V					
Temperature Increase °C	M I N	+8	M E D	+18	M A X	+25
Power (kw/hour)	M I N	3	M E D	7,8	M A X	10,8
Theoretical consumption (Amp)	M I N	13,5	M E D	35,5	M A X	49
Water pressure	Minimum 3 PSI   Maximum 85 PSI					
Water flow @ 25°C	6 Lts/min					
Water connection (W' NPT)	Cold [right side]   Hot [left side]					
Dimensions	32 x 23 x 13cm					
Net weight	3,4 kg					
Electrical connections (Rule back)	Green O GROUND[+J	Left S LINE[L1J	Right S LINE[L2)			



## 1.5 Electric Diagram

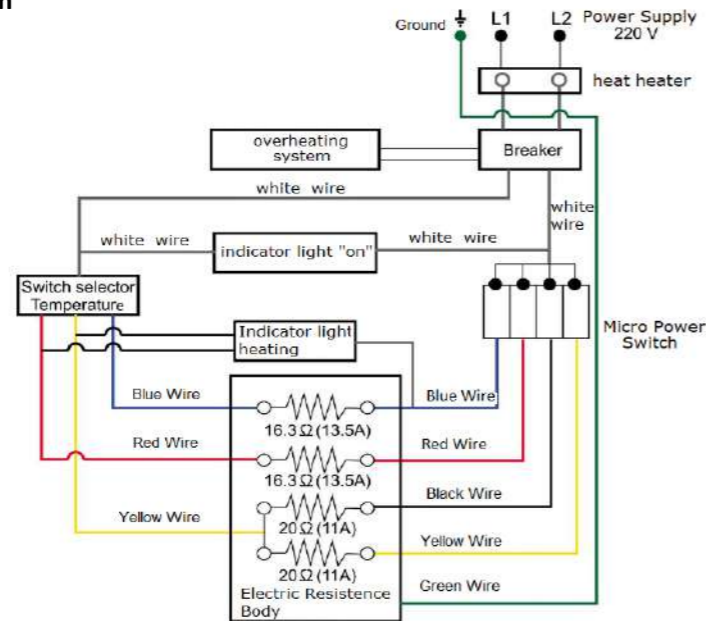

## 1. Instalation

### 2.1 Accessories (included in the package)

- 3 Srew and plastic plugs for fixing.
- 1 Metal bracket for fixing to wall.

### 2.2 Place of Assembly

It is recommended to place your Norwik heater as close as possible to the hot water supply point. In a place of easy access for future maintenance.

The heater should not be installed in the vicinity where it receives sun or rain directly, or where the ambient temperature may drop below 0 ° C.

### 2.3 Heater Assembly

Fix the metal bracket to the wall using 2 screws and the plastic plugs in the package. Hang the heat er once the electrical connection (see electrical installation). Completely fix the cooling fan with the third screw (included in the package) into the lower dimple located between the water connections.

## 2.4 Water connections

The cold water piping and hot water piping should be clearly identified, both located at the bottom of the unit.

The cold water intake is on the right side of your heater and the hot water outlet is located on the left side of the heater.

It is advisable to pre-purge the cold water pipe before connecting it to remove impurities contained in the pipes and prevent obstructions in the heater.

The hot and cold water connection nipple is 1/2 "NPT male thread. The connection may be made with hot water resistant PVC pipe or copper pipe, provided that a locking wrench is placed in the cold water inlet.

The minimum water pressure should be 3 PSI or 2 meters water column, if the pressure is lower than indicated the water valve will prevent the automatic ignition of the apparatus to avoid internal damage.

## 2.5 Electrical Installation

Check that the supply voltage of the heater is the same as that indicated on the label of technical characteristics found on the right side of your Norwik heater, ie 220 volts.

During electrical installation make sure that the heater breaker is in the "off" position as well as the temperature setting selector.

Disconnect the power supply from the main board, place a 2x60 Amp breaker on the heater board, and store two electrical wires from the board breaker to the # 8 Awg heater for lines L1 and L2 (DO NOT USE CABLE OF CALIBER LESS THAN 8 AWG) and a # 10 Awg wire for the ground connection.

These cables must be connected to the heater through the terminal strip located on the back of the heater according to the following diagram.

Green ○ GROUND(,)	LEFT @ LINE(L1)	RIGHT @ LINE(L2)
-------------------------	-----------------------	------------------------

Once the wires have been connected, check that the screws on the connector board of both the heater and board breaker are firmly tightened.